

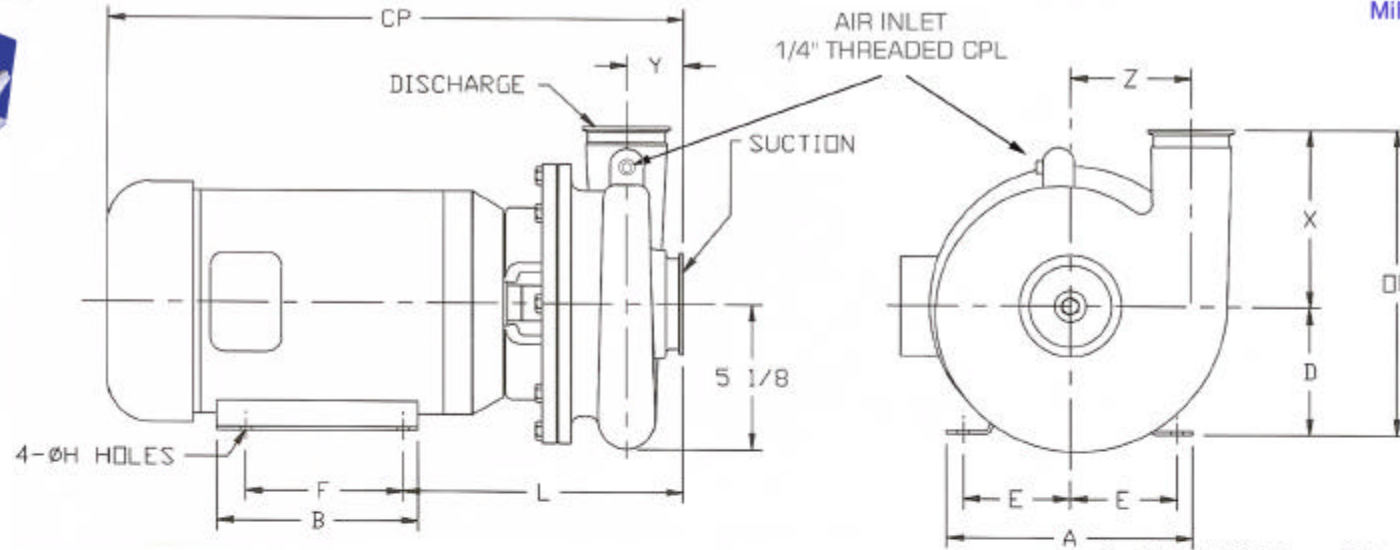

KT - M Series Dimensions



Subtract 1/2" from CP and Y for the 4 X 2-1/2 X 8i

PUMP	HP	RPM	Frame	A (max)	B (max)	D	E	F	H	L	CP	OP	X	Y	Z
2x1-1/2	2	3500	145JM	6-1/2	6	3-1/2	2-3/4	5	11/32	8-7/8	17-1/4	9-3/4	6 1/4	2	3 3/4
	3	3500	145JM	6-1/2	6	3-1/2	2-3/4	5	11/32	8-7/8	17-1/4	9-3/4			
	5	3500	184JM	8-5/8	6-1/2	4-1/2	3-3/4	5-1/2	13/32	9-1/2	20-1/8	10-3/4			
	7.5	3500	184JM	8-5/8	6-1/2	4-1/2	3-3/4	5-1/2	13/32	9-1/2	21-5/8	10-3/4			
	10	3500	215JM	9-1/2	8	5-1/4	4-1/4	7	13/32	10-1/2	21-5/8	11-1/2			
2-1/2x2	2	3500	145JM	6-1/2	6	3-1/2	2-3/4	5	11/32	8-7/8	17-1/4	9-3/4	6 1/4	2	4
	3	3500	145JM	6-1/2	6	3-1/2	2-3/4	5	11/32	8-7/8	17-1/4	9-3/4			
	5	3500	184JM	8-5/8	6-1/2	4-1/2	3-3/4	5-1/2	13/32	9-1/2	20-1/8	10-3/4			
	7.5	3500	184JM	8-5/8	6-1/2	4-1/2	3-3/4	5-1/2	13/32	9-1/2	21-5/8	10-3/4			
	10	3500	215JM	9-1/2	8	5-1/4	4-1/4	7	13/32	10-1/2	21-5/8	11-1/2			
3x2-1/2x7i	5	3500	184JM	8-5/8	6-1/2	4-1/2	3-3/4	5-1/2	13/32	9-7/8	20-1/2	10-3/4	6 1/4	2	4 1/4
	7.5	3500	184JM	8-5/8	6-1/2	4-1/2	3-3/4	5-1/2	13/32	9-7/8	21-7/8	10-3/4			
	10	3500	215JM	9-1/2	8	5-1/4	4-1/4	7	13/32	10-7/8	21-7/8	11-1/2			
	15	3500	215JM	9-1/2	8	5-1/4	4-1/4	7	13/32	10-7/8	23-1/8	11-1/2			
	20	3500	256JM	11-1/2	11-1/2	6-1/4	5	10	17/32	12-3/8	27	12-1/2			
3x2-1/2x8i and 4x2-1/2x8i	15	3500	254JM	11-1/2	9-3/4	6-1/4	5	8-1/4	17/32	12-1/2	25-1/4	11-7/8	5 5/8	2 17/32	5 1/16
	20	3500	256JM	11-1/2	11-1/2	6-1/4	5	10	17/32	12-1/2	27	11-7/8			
	25	3500	284JM	12-3/4	12-3/4	7	5-1/2	9-1/2	17/32	12-1/2	30-7/8	12-5/8			
	30	3500	286JM	12-3/4	12-3/4	7	5-1/2	11	17/32	12-1/2	30-7/8	12-5/8			
	40	3500	324JM	14-1/2	14	8	6-1/4	10-1/2	21/32	13	32-3/4	13-5/8			
	50	3500	326JM	14-1/2	14	8	6-1/4	12	21/32	13	32-3/4	13-5/8			
	60	3500	364JM	16-1/2	14-1/2	9	7	11-1/4	21/32	13-7/8	34-3/4	14-5/8			
75	3500	365JM	16-1/2	14-1/2	9	7	12-1/4	21/32	13-7/8	34-3/4	14-5/8				